

Spur gear winch TL1000-1500



Spur gear winch

Product specifications:

- robust and safe hoisting winch
- static safety factor 4
- load pressure brake with double ratchet system
- maintenance free bearings
- adjustable crank with ergonomic grip
- cable outlet upwards, downwards or at the left
- closed gearbox
- in compliance with EN13157, DIN 15020 and EX types ATEX 114 (94/9/EG)
- paint thickness is 60 - 80 micron in 1 layer and in compliance with DIN/ISO 12944, C1M

Options:

- stainless steel SAE grade 304
- ATEX certified  II 3 GD T3, zone 2 and 22
- multiple cable drum compartments

Accessories:

- steel or stainless steel wire ropes
- pulley blocks suitable for hand winches

GEBUWIN
metal products

Industrieweg 6, 7102 DZ Winterswijk, The Netherlands
Telephone: +31(0)543 532600 Email: info@gebuwin.com
For more information: www.gebuwin.com



Technical specifications TL1000-1500

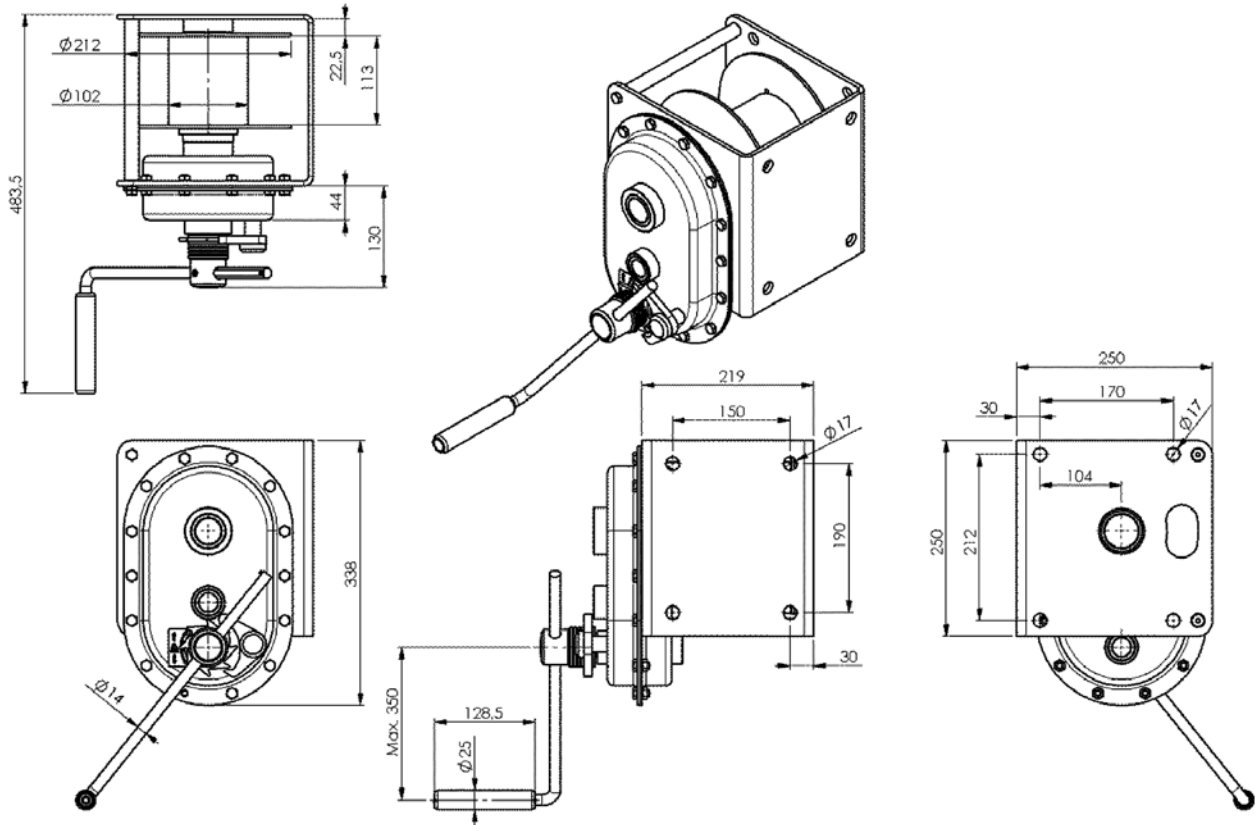

Type	Mounting	Material finish	Remarks
TL1000 - 1500 GR	Wall, 4x M12 class 8.8	Painted finish	RAL 7035 (grey)
TL1000 - 1500 SS	Wall, 4x M12 class 8.8	Stainless steel	

Technical specifications		TL1000	TL1500
Capacity 1st cable layer	kg	1000	1500
Capacity last cable layer	kg	614	927
Crankforce 1st cable layer	daN	11	12
Hoisting length one rotation, 1st layer	mm	20	14
Max. cable storage (one cable drum)	m	33	21
Diameter cable	mm	8	10
Min. breaking load cable	kN	30	45
Own weight	kg	27	27,5

subject to changes

Form more information: www.gebuwin.com