

## Spur gear winch TC1000-1500 freespool



## Spur gear console winch

### Product specifications:

- robust and safe pulling and hoisting winch
- pulling capacity is approx. 2,5x hoisting capacity
- static safety factor 4
- load pressure brake with double ratchet system
- maintenance free bearings
- adjustable crank with ergonomic grip
- cable outlet upwards, left or right
- closed gearbox
- with free spool lever (FS)
- in compliance with EN13157, DIN 15020 and EX types ATEX 114 (94/9/EG)
- paint thickness is 60 - 80 micron in 1 layer and in compliance with DIN/ISO 12944, C1M

### Options:

- stainless steel SAE grade 304
- ATEX certified  II 3 GD T3, zone 2 and 22
- multiple cable drum compartments

### Accessories:

- steel or stainless steel wire ropes
- pulley blocks suitable for hand winches



**GEBUWIN**  
metal products

Industrieweg 6, 7102 DZ Winterswijk, The Netherlands  
Telephone: +31(0)543 532600 Email: [info@gebuwin.com](mailto:info@gebuwin.com)  
For more information: [www.gebuwin.com](http://www.gebuwin.com)



## Technical specifications TC1000-1500 / FS

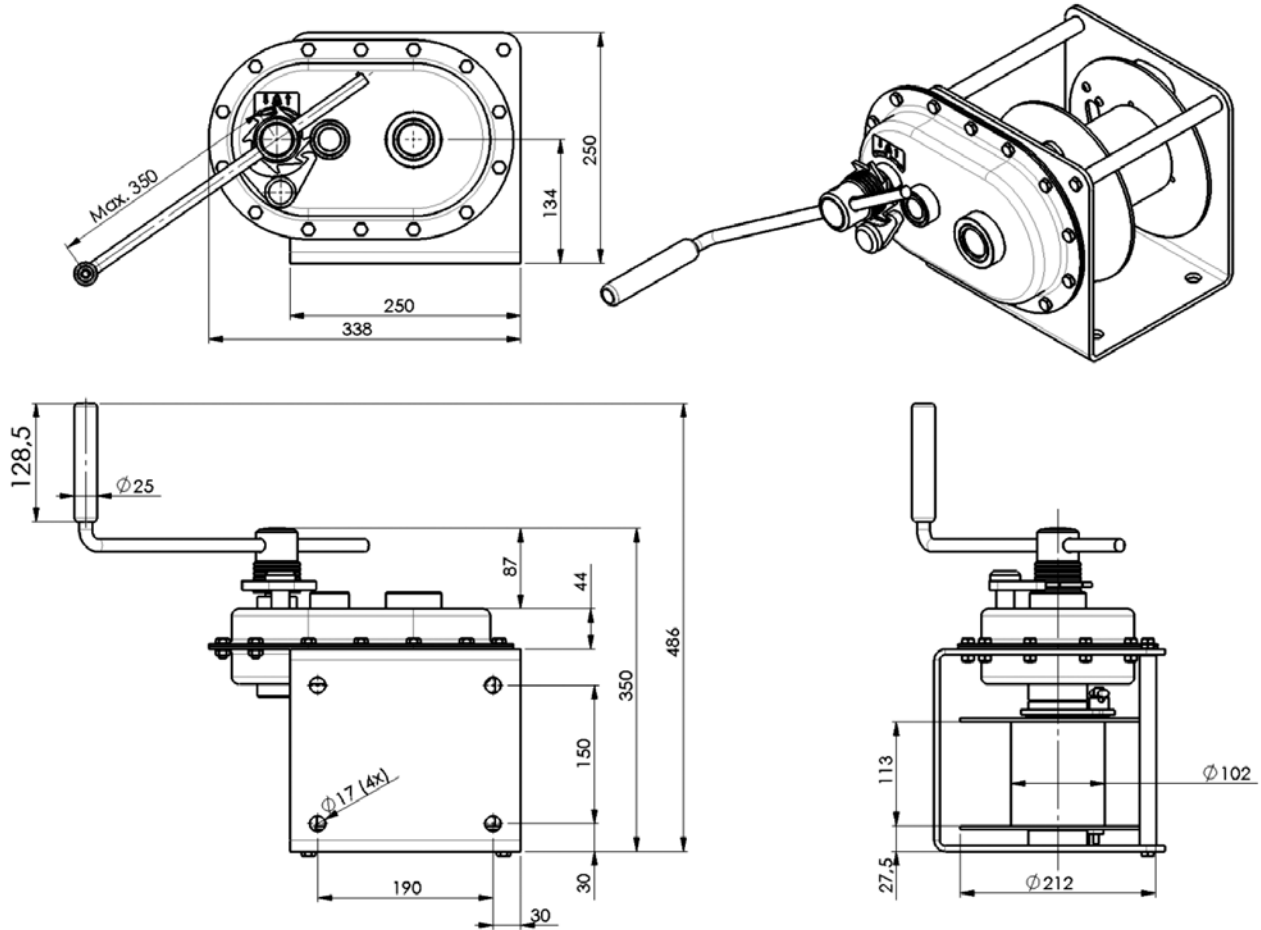

Type	Mounting	Material finish	Remarks
TC1000 - 1500 GR / FS	Console, 4x M12 class 8.8	Painted finish	RAL 7035 (grey)
TC1000 - 1500 SS / FS	Console, 4x M12 class 8.8	Stainless steel 304	

Technical specifications		TC1000	TC1500
Capacity 1st cable layer	kg	1000	1500
Capacity last cable layer	kg	614	927
Crankforce 1st cable layer	daN	11	12
Hoisting length one rotation, 1st layer	mm	20	14
Max. cable storage (one cable drum)	m	33	21
Diameter cable	mm	8	10
Min. breaking load cable	kN	30	45
Own weight	kg	27	27,5

subject to changes

Form more information: [www.gebuwin.com](http://www.gebuwin.com)